

GREENVILLE AWNING CO.

GHRC-200



① Canopy Isometric View

GREENVILLE
AWNING COMPANY
(864) 288-0063

GHRC-200

SCALE:N/A	APPROVED BY:	DRAWN BY: ES
DATE: 4/23/19		REVISION:
FOR:		Drawing Number: 1 of 13

THESE DRAWINGS WERE PREPARED BY AND ARE THE SOLE PROPERTY OF GREENVILLE AWNING COMPANY. UNAUTHORIZED USE OR REPRODUCTIONS IS STRICTLY PROHIBITED. GREENVILLE AWNING COMPANY ©

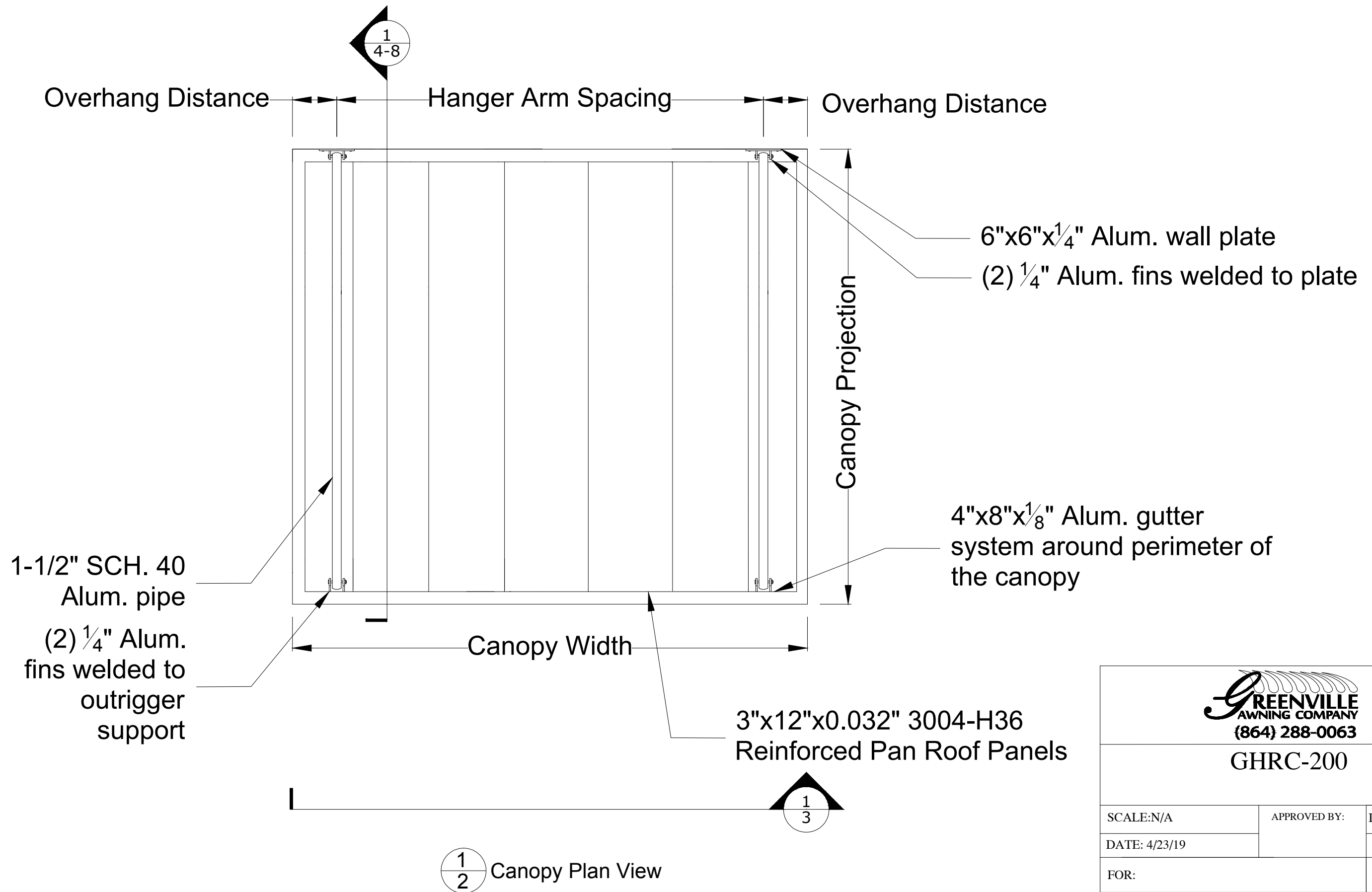

GHRC-200

SCALE:N/A	APPROVED BY:	DRAWN BY: ES
DATE: 4/23/19		REVISION:
FOR:		Drawing Number: 2 of 13

THESE DRAWINGS WERE PREPARED BY AND ARE THE SOLE PROPERTY OF GREENVILLE AWNING COMPANY. UNAUTHORIZED USE OR REPRODUCTIONS IS STRICTLY PROHIBITED. GREENVILLE AWNING COMPANY ©

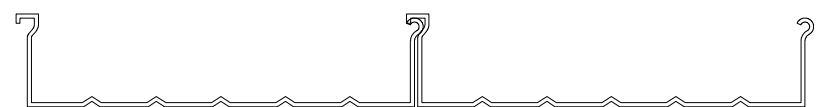
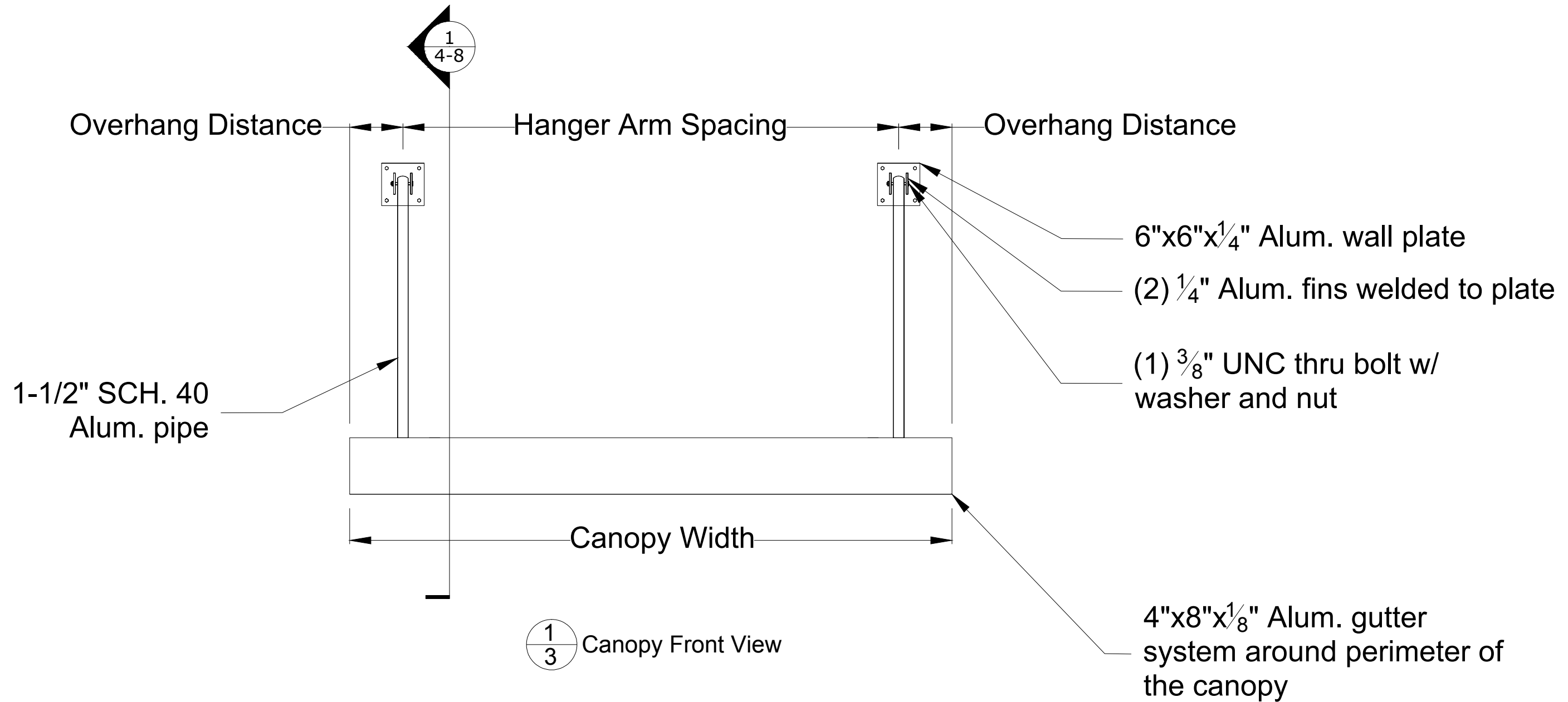

3"x12"x.032" 3004-H36 Reinforced Pan Roof Panels

2
3 Decking Detail



GHRC-200

SCALE:N/A	APPROVED BY:	DRAWN BY: ES
DATE: 4/23/19		REVISION:
FOR:		Drawing Number: 3 of 13

THESE DRAWINGS WERE PREPARED BY AND ARE THE SOLE PROPERTY OF GREENVILLE AWNING COMPANY. UNAUTHORIZED USE OR REPRODUCTIONS IS STRICTLY PROHIBITED. GREENVILLE AWNING COMPANY ©

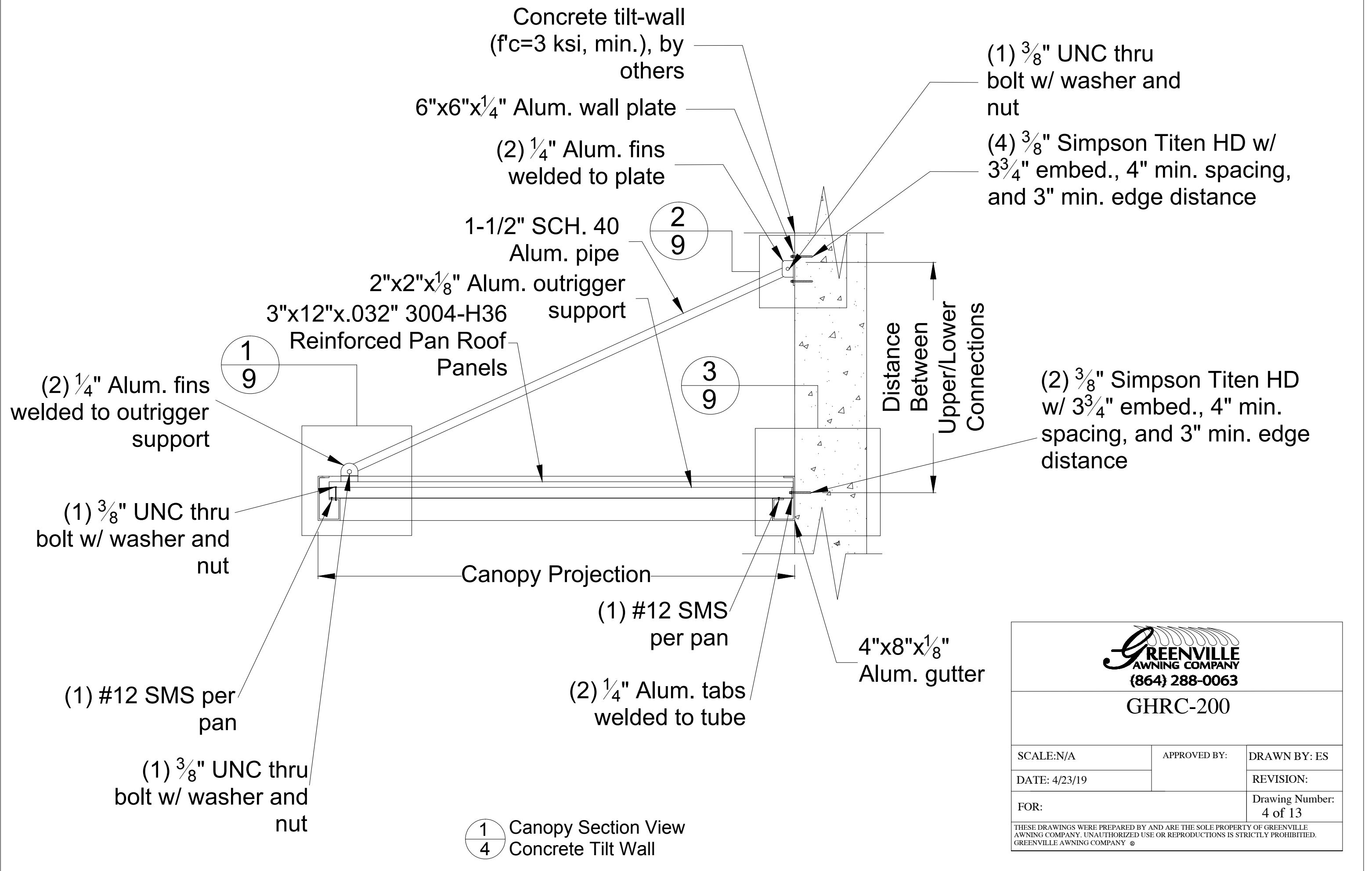

GHRC-200

SCALE:N/A	APPROVED BY:	DRAWN BY: ES
DATE: 4/23/19		REVISION:
FOR:		Drawing Number: 4 of 13

THESE DRAWINGS WERE PREPARED BY AND ARE THE SOLE PROPERTY OF GREENVILLE AWNING COMPANY. UNAUTHORIZED USE OR REPRODUCTIONS IS STRICTLY PROHIBITED. GREENVILLE AWNING COMPANY ©

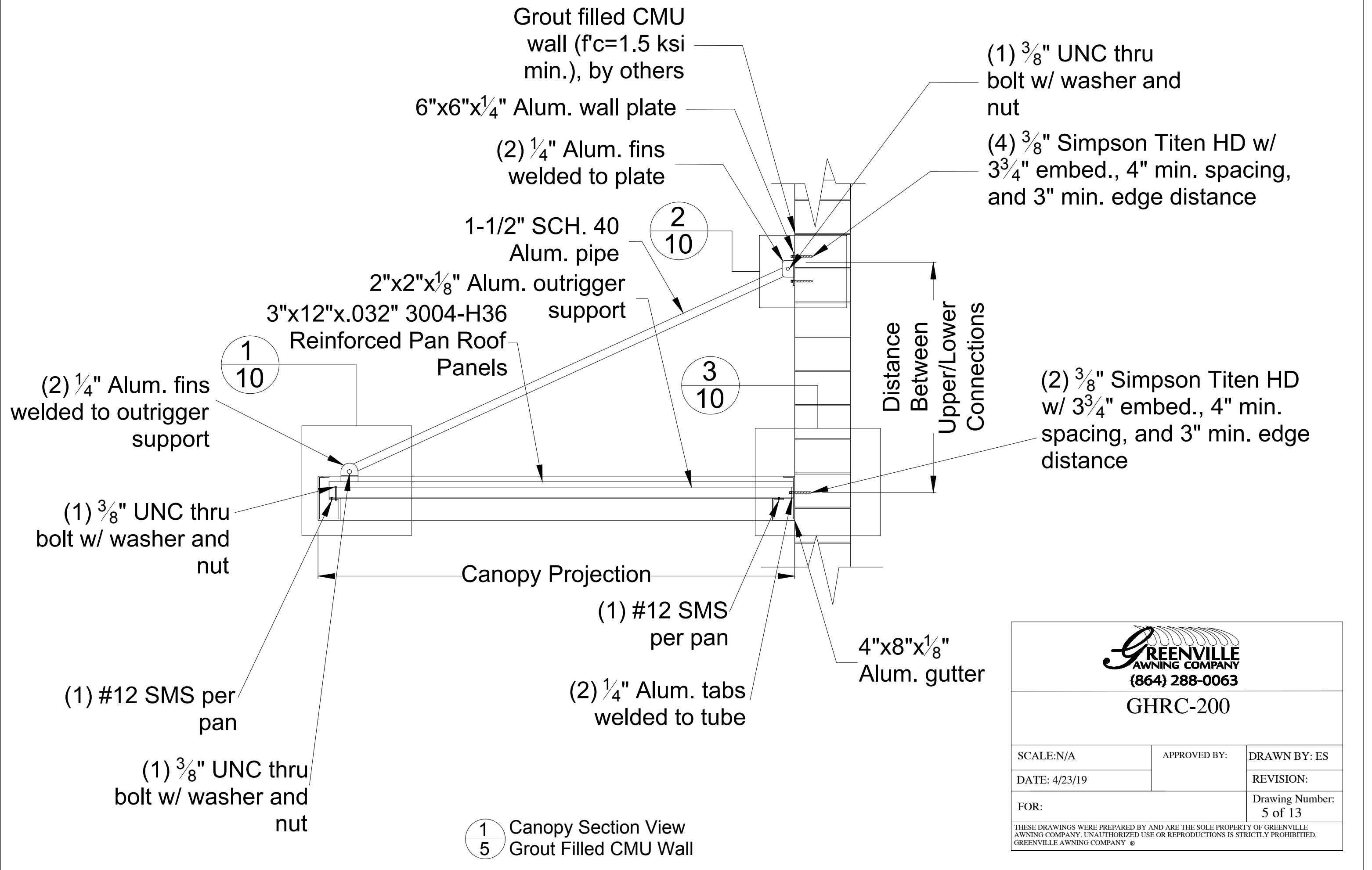

GHRC-200

SCALE:N/A	APPROVED BY:	DRAWN BY: ES
DATE: 4/23/19		REVISION:
FOR:		Drawing Number: 5 of 13

THESE DRAWINGS WERE PREPARED BY AND ARE THE SOLE PROPERTY OF GREENVILLE AWNING COMPANY. UNAUTHORIZED USE OR REPRODUCTIONS IS STRICTLY PROHIBITED. GREENVILLE AWNING COMPANY ©

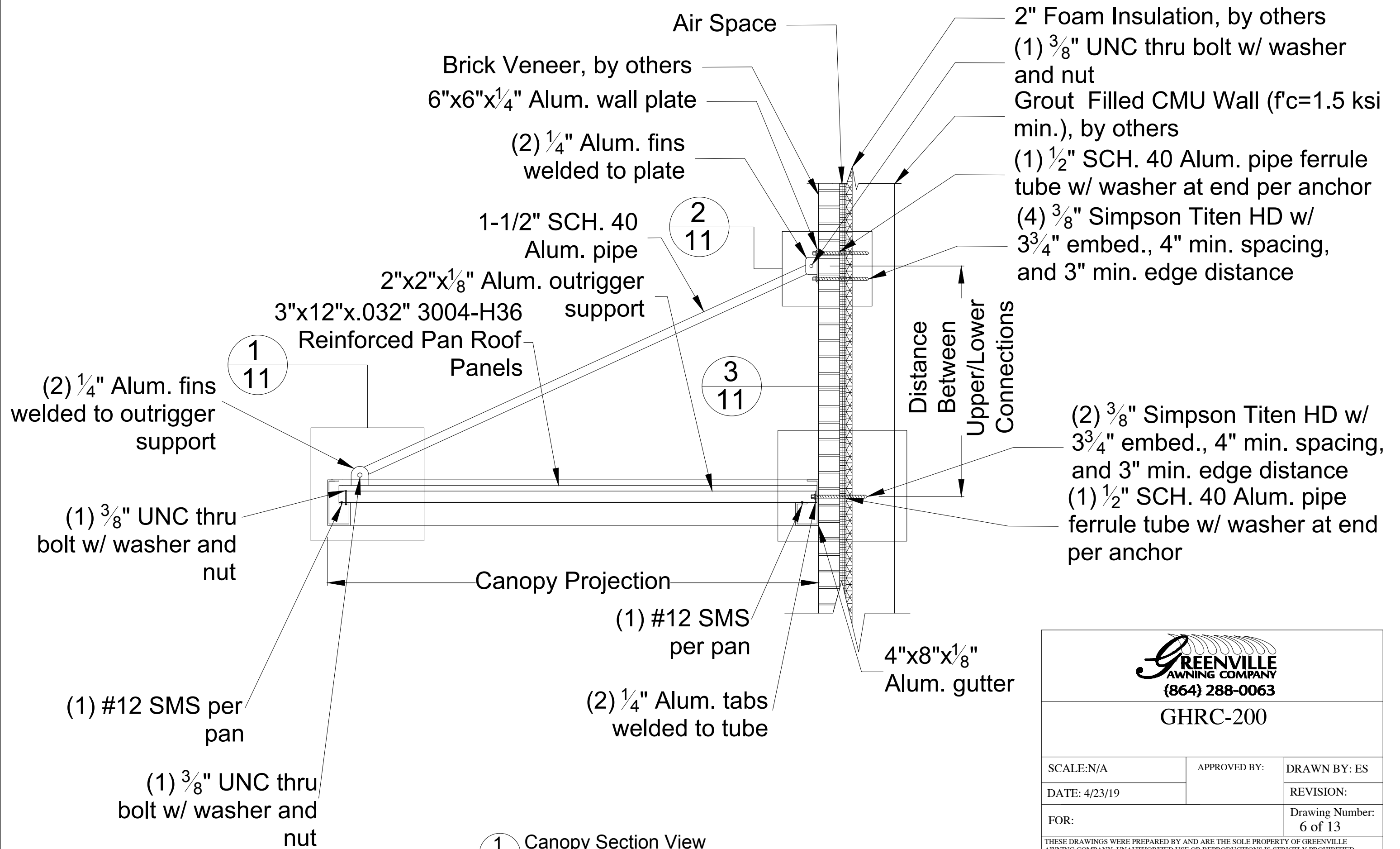

1 Canopy Section View
6 Brick Veneer Wall

GREENVILLE
AWNING COMPANY
(864) 288-0063

GHRC-200

SCALE: N/A	APPROVED BY:	DRAWN BY: ES
DATE: 4/23/19		REVISION:
FOR:		Drawing Number: 6 of 13
THESE DRAWINGS WERE PREPARED BY AND ARE THE SOLE PROPERTY OF GREENVILLE AWNING COMPANY. UNAUTHORIZED USE OR REPRODUCTIONS IS STRICTLY PROHIBITED. GREENVILLE AWNING COMPANY ©		

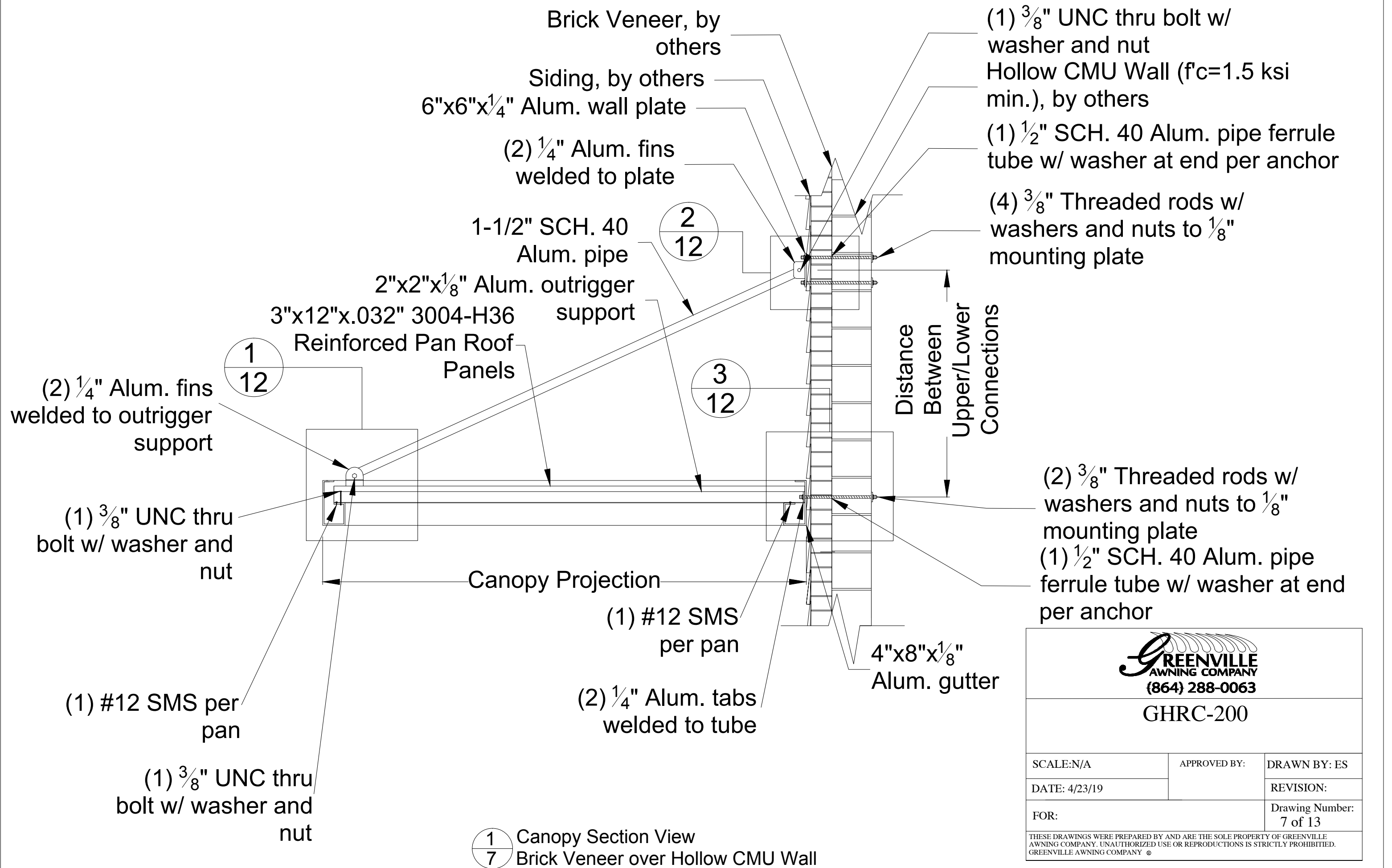

GHRC-200

SCALE:N/A	APPROVED BY:	DRAWN BY: ES
DATE: 4/23/19		REVISION:
FOR:		Drawing Number: 7 of 13

THESE DRAWINGS WERE PREPARED BY AND ARE THE SOLE PROPERTY OF GREENVILLE AWNING COMPANY. UNAUTHORIZED USE OR REPRODUCTIONS IS STRICTLY PROHIBITED. GREENVILLE AWNING COMPANY ©

1 Canopy Section View
 7 Brick Veneer over Hollow CMU Wall

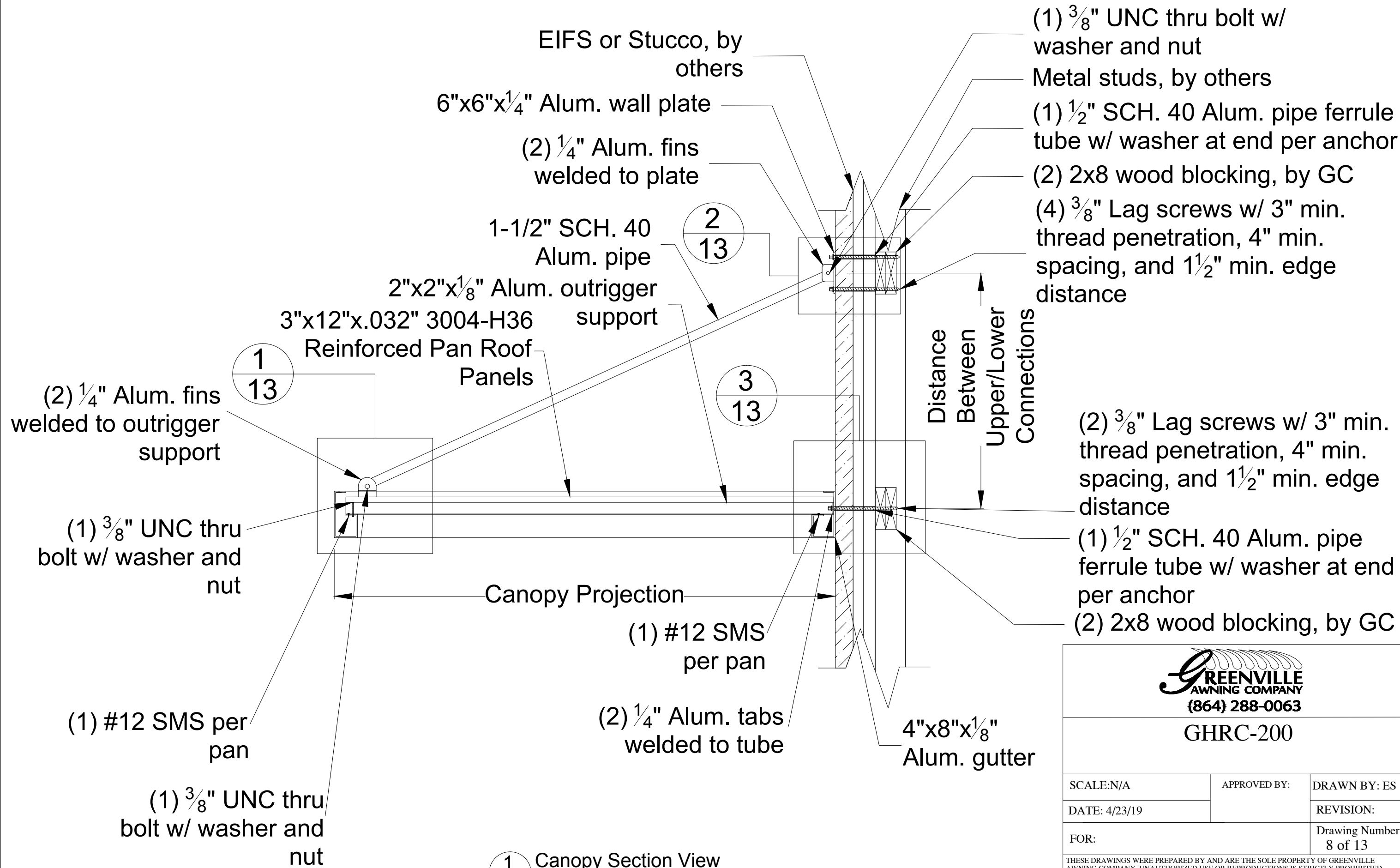

1 Canopy Section View
 8 EIFS or Stucco Wall over Wood Blocking

GREENVILLE
 AWNING COMPANY
 (864) 288-0063

GHRC-200

SCALE: N/A	APPROVED BY:	DRAWN BY: ES
DATE: 4/23/19		REVISION:
FOR:		Drawing Number: 8 of 13

THESE DRAWINGS WERE PREPARED BY AND ARE THE SOLE PROPERTY OF GREENVILLE AWNING COMPANY. UNAUTHORIZED USE OR REPRODUCTIONS IS STRICTLY PROHIBITED. GREENVILLE AWNING COMPANY ©

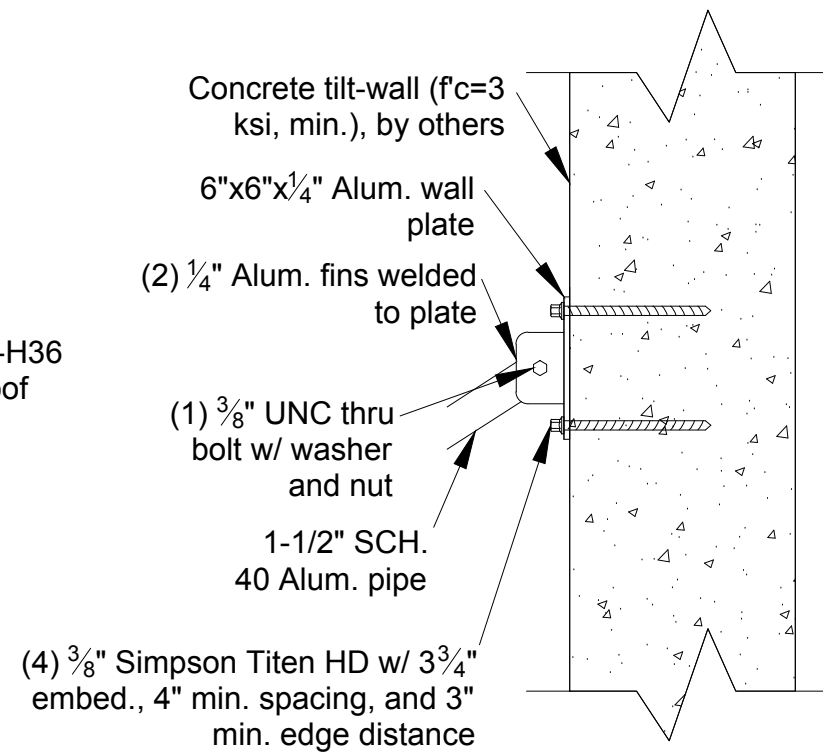
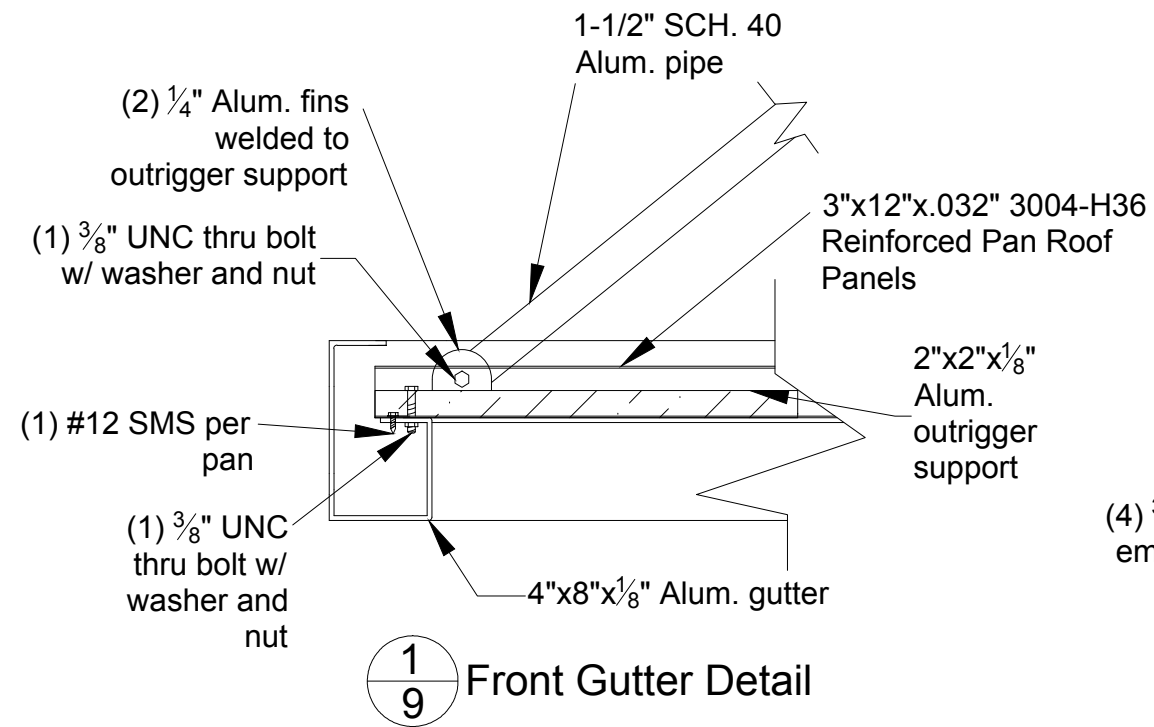

2/9 Wall Bracket Detail

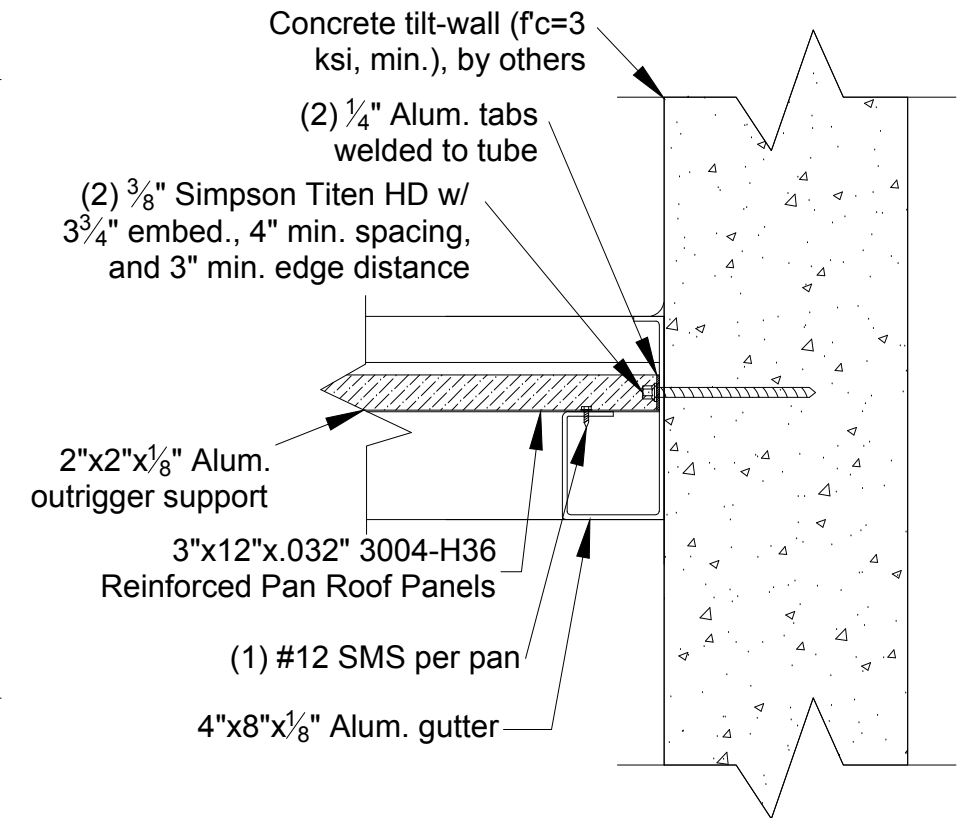

3/9 Rear Gutter Detail



GHRC-200

SCALE:N/A	APPROVED BY:	DRAWN BY: ES
DATE: 4/23/19		REVISION:
FOR:	Drawing Number: 9 of 13	

THESE DRAWINGS WERE PREPARED BY AND ARE THE SOLE PROPERTY OF GREENVILLE AWNING COMPANY. UNAUTHORIZED USE OR REPRODUCTIONS IS STRICTLY PROHIBITED. GREENVILLE AWNING COMPANY ©

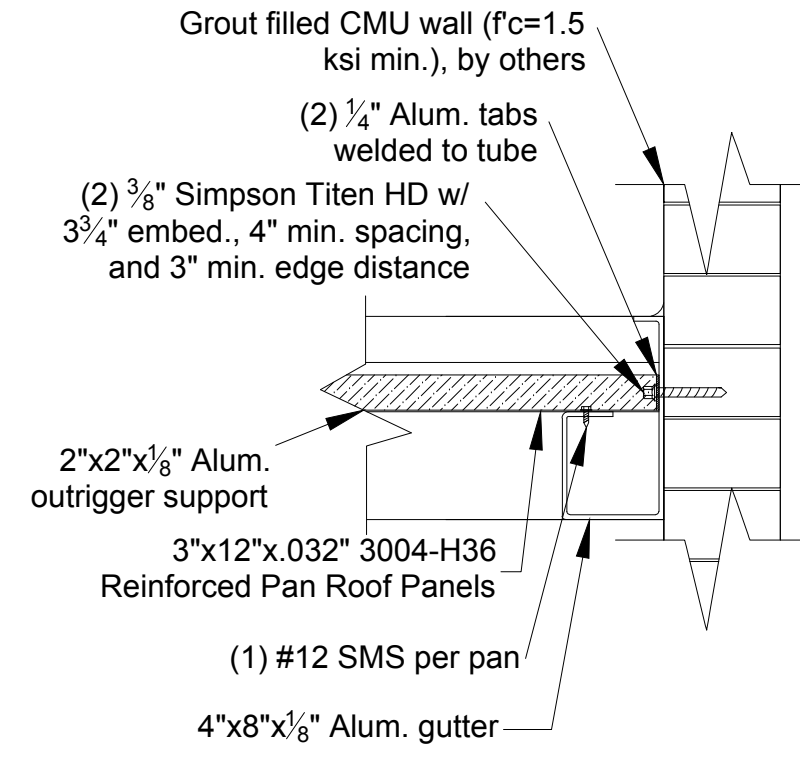
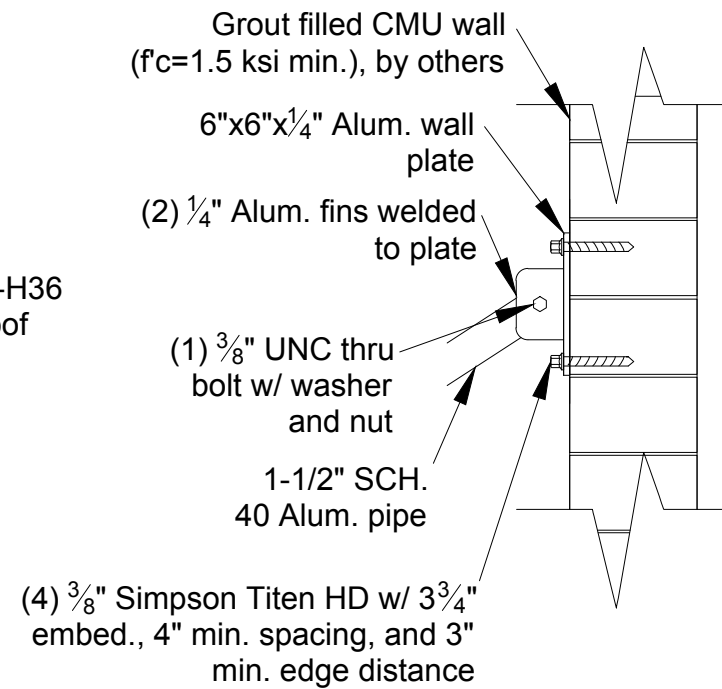
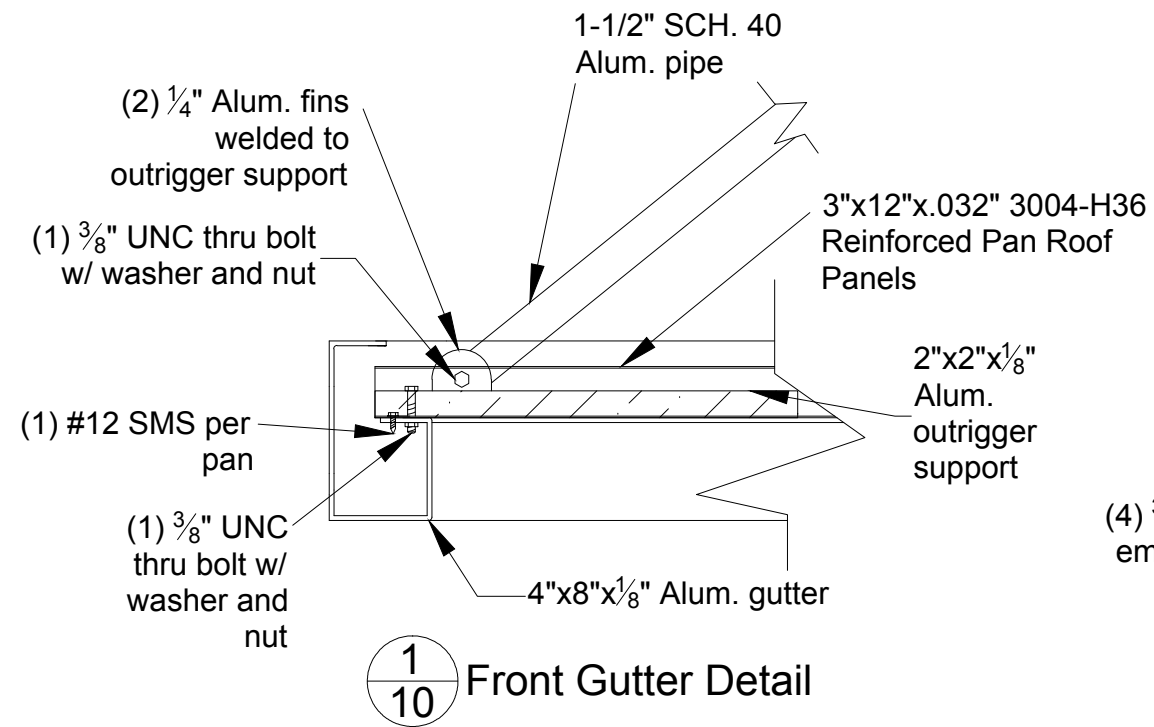

GHRC-200

SCALE:N/A	APPROVED BY:	DRAWN BY: ES
DATE: 4/23/19		REVISION:
FOR:	Drawing Number: 10 of 13	

THESE DRAWINGS WERE PREPARED BY AND ARE THE SOLE PROPERTY OF GREENVILLE AWNING COMPANY. UNAUTHORIZED USE OR REPRODUCTIONS IS STRICTLY PROHIBITED. GREENVILLE AWNING COMPANY ©

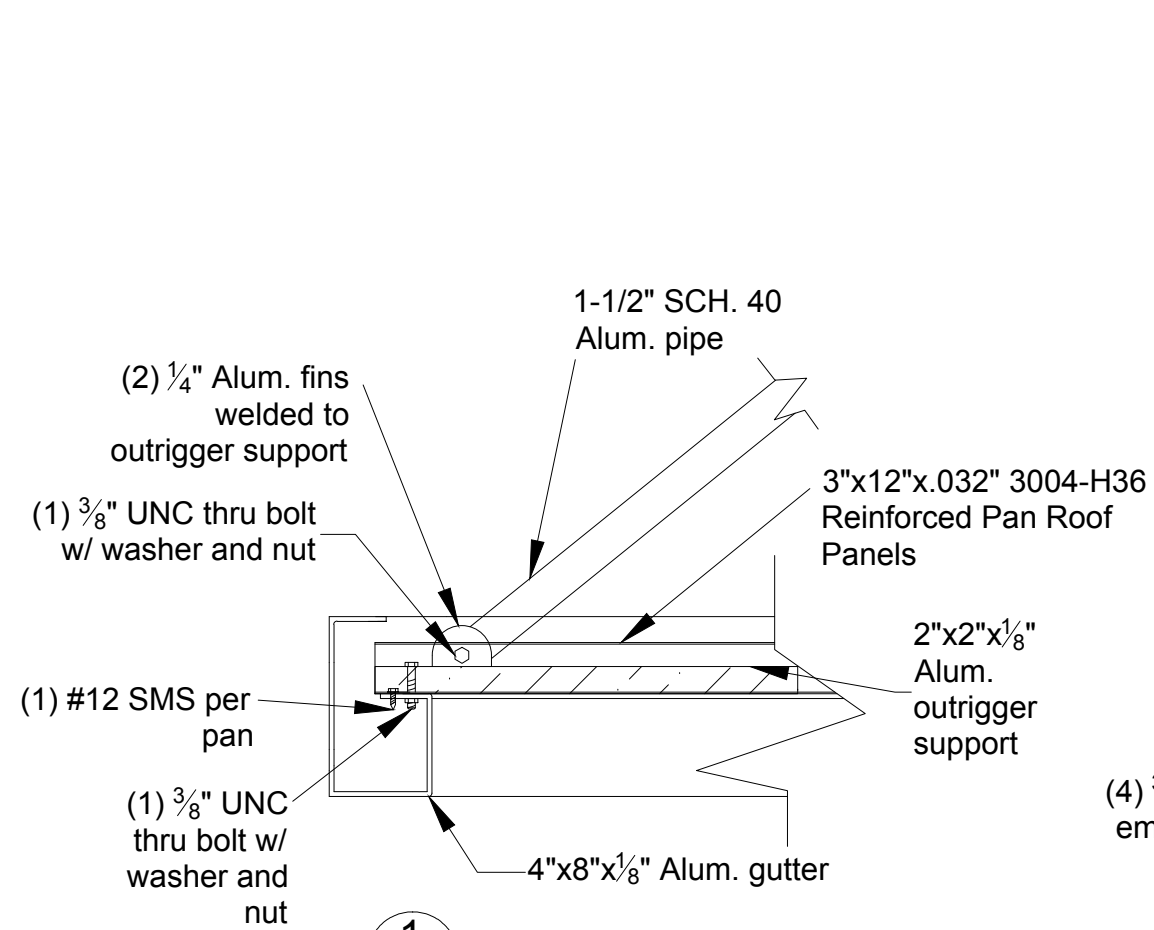

1
11 Front Gutter Detail

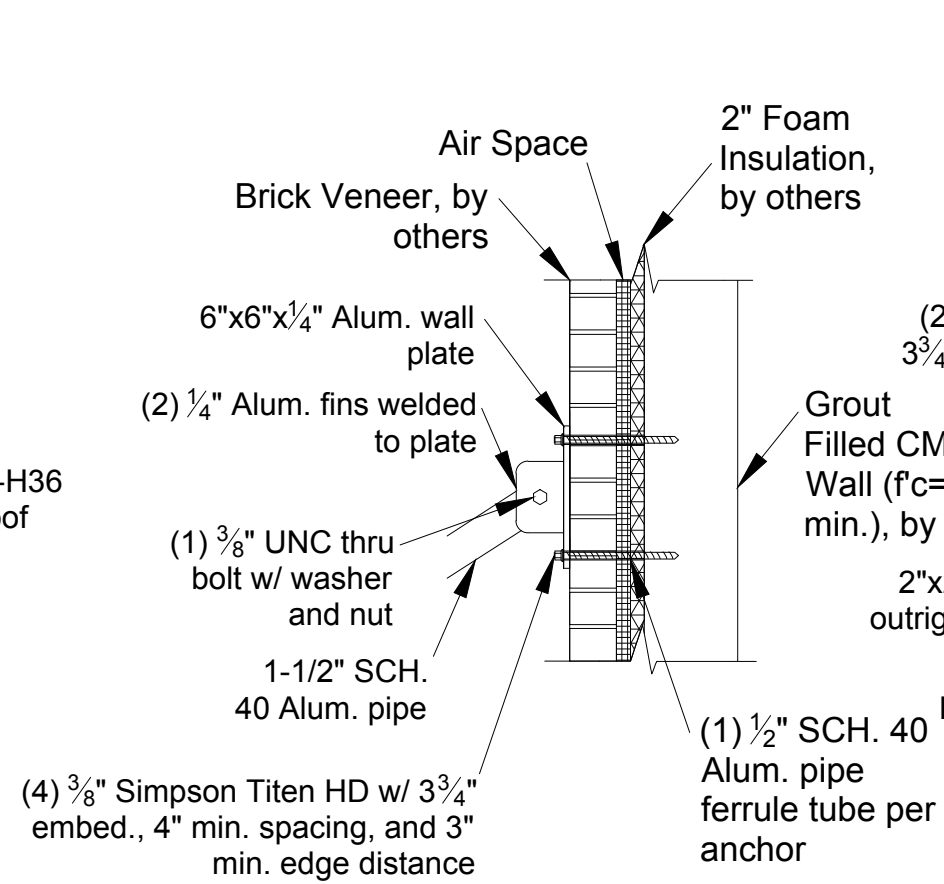

2
11 Wall Bracket Detail

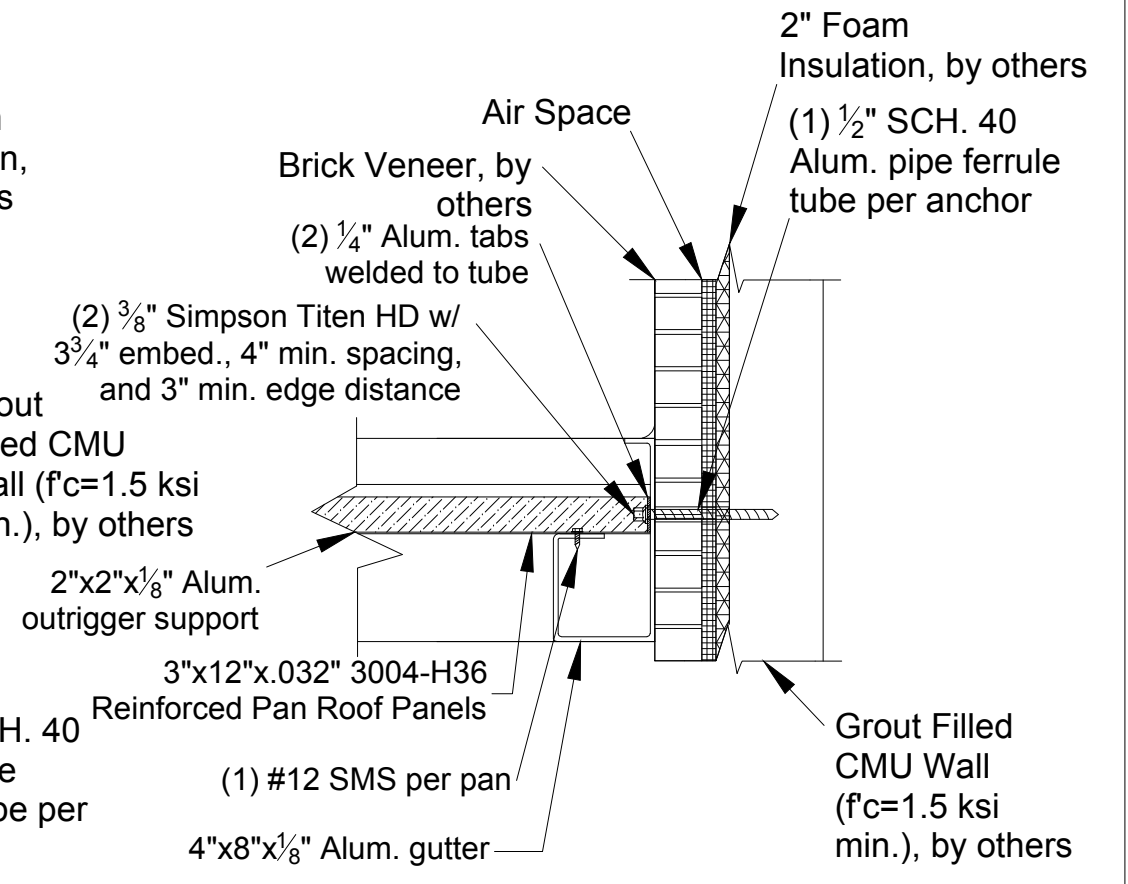

3
11 Rear Gutter Detail



GHRC-200

SCALE:N/A	APPROVED BY:	DRAWN BY: ES
DATE: 4/23/19		REVISION:
FOR:		Drawing Number: 11 of 13

THESE DRAWINGS WERE PREPARED BY AND ARE THE SOLE PROPERTY OF GREENVILLE AWNING COMPANY. UNAUTHORIZED USE OR REPRODUCTIONS IS STRICTLY PROHIBITED. GREENVILLE AWNING COMPANY ©

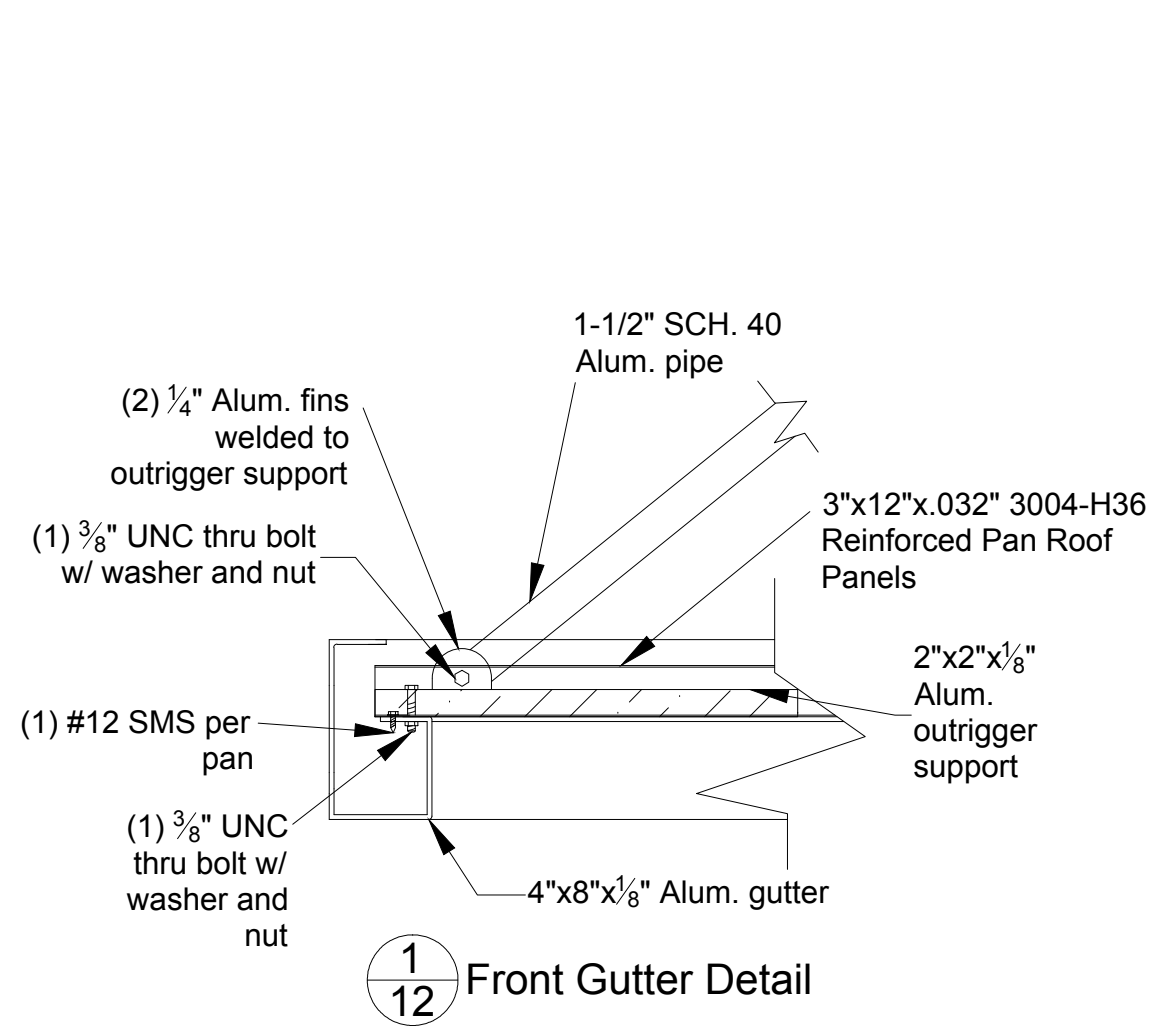

1/12 Front Gutter Detail

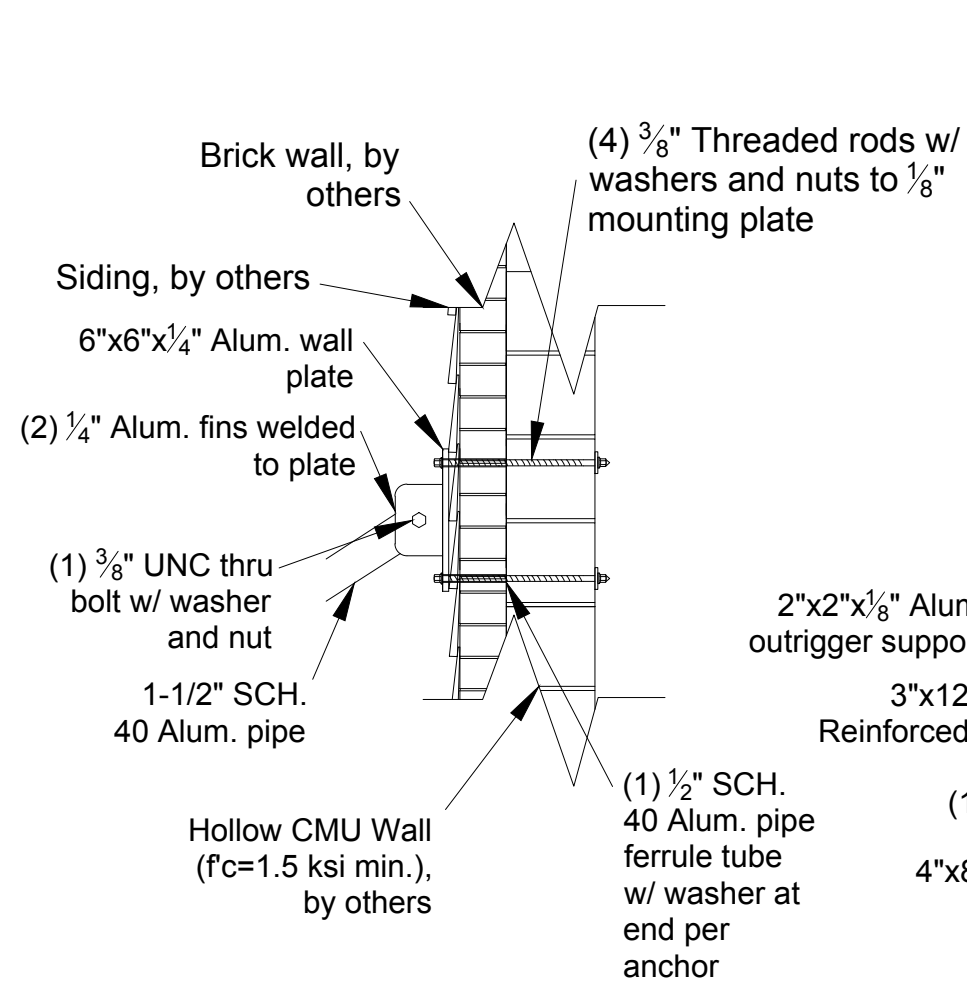

2/12 Wall Bracket Detail

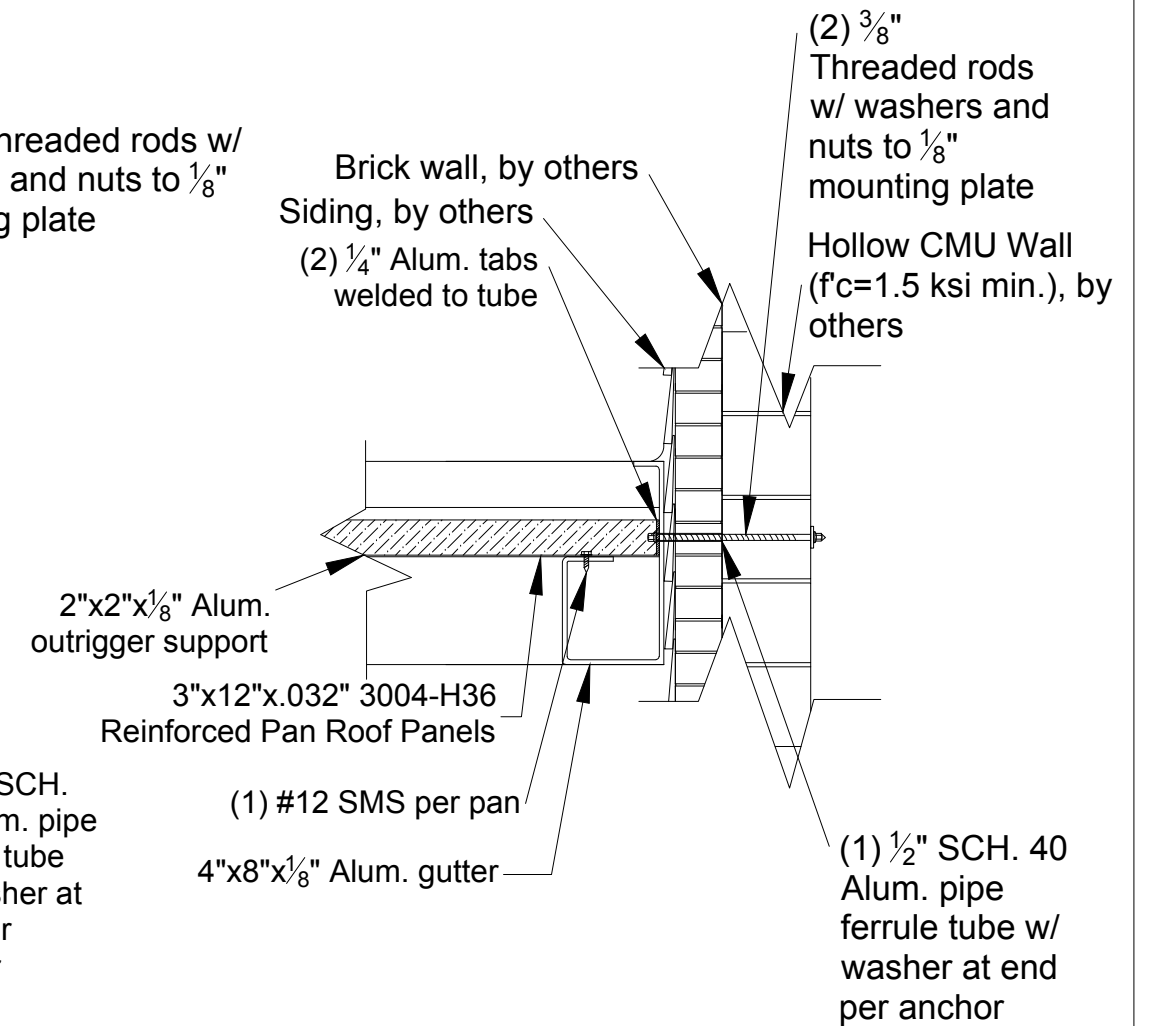

3/12 Rear Gutter Detail



GHRC-200

SCALE:N/A	APPROVED BY:	DRAWN BY: ES
DATE: 4/23/19		REVISION:
FOR:	Drawing Number: 12 of 13	

THESE DRAWINGS WERE PREPARED BY AND ARE THE SOLE PROPERTY OF GREENVILLE AWNING COMPANY. UNAUTHORIZED USE OR REPRODUCTIONS IS STRICTLY PROHIBITED. GREENVILLE AWNING COMPANY ©

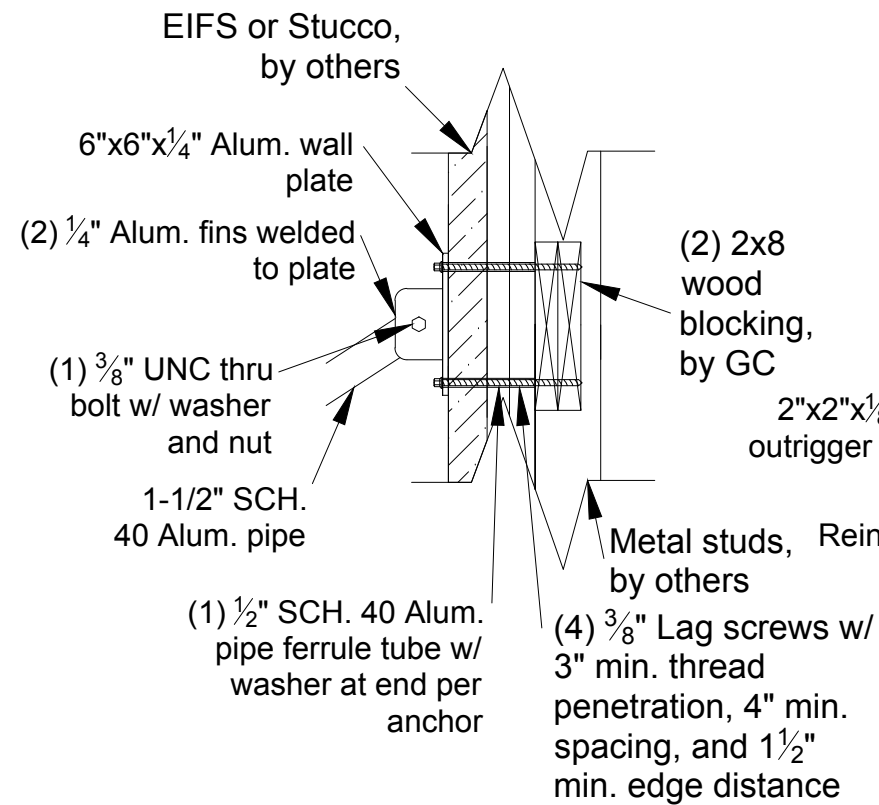
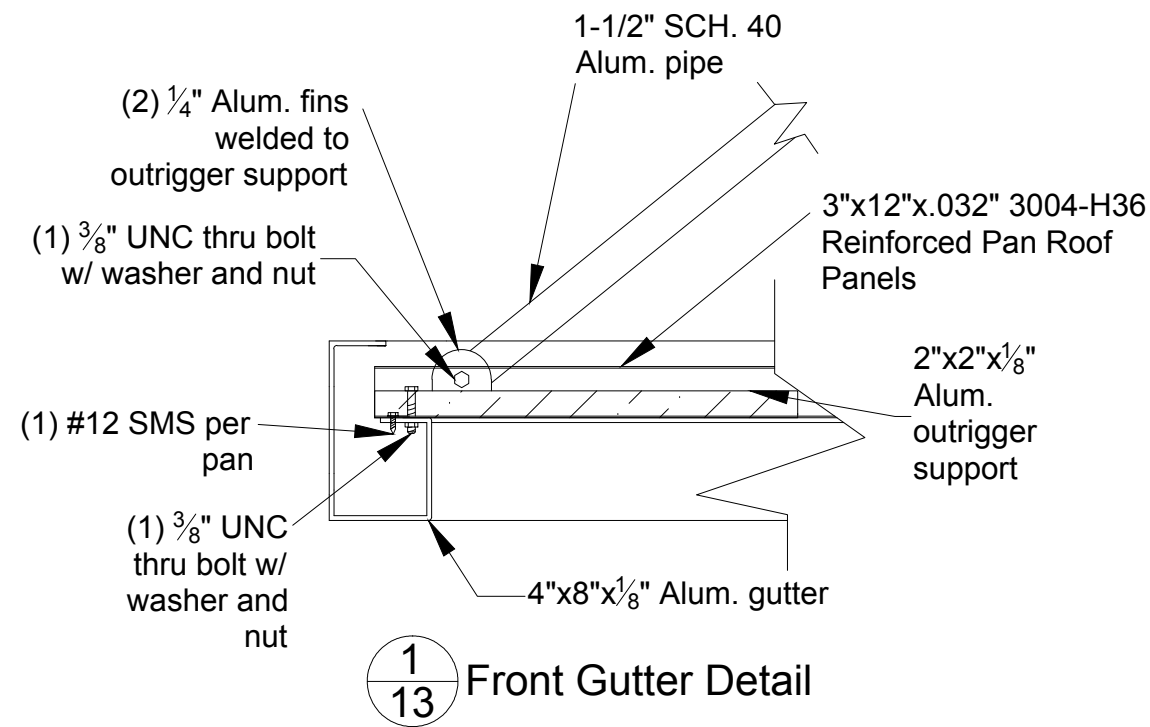

2
13 Wall Bracket Detail

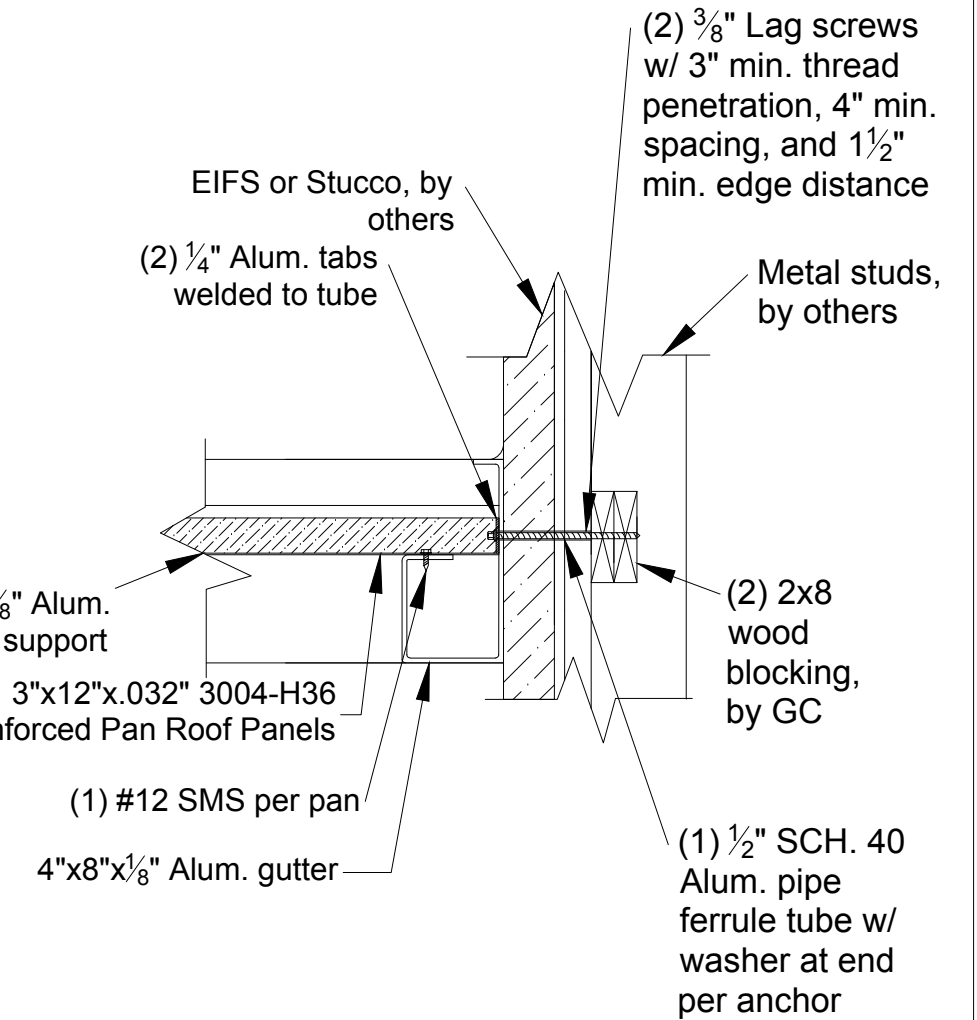

3
13 Rear Gutter Detail



GHRC-200

SCALE:N/A	APPROVED BY:	DRAWN BY: ES
DATE: 4/23/19		REVISION:
FOR:	Drawing Number: 13 of 13	

THESE DRAWINGS WERE PREPARED BY AND ARE THE SOLE PROPERTY OF GREENVILLE AWNING COMPANY. UNAUTHORIZED USE OR REPRODUCTIONS IS STRICTLY PROHIBITED. GREENVILLE AWNING COMPANY ©